

Spring plungers with hexagon socket and ball, steel

Item description/product images



Description

Material:

Sleeve steel grade 5.8.

Ball steel.

Spring grade D steel wire.

Version:

Black oxidised. Ball hardened.

column indexing

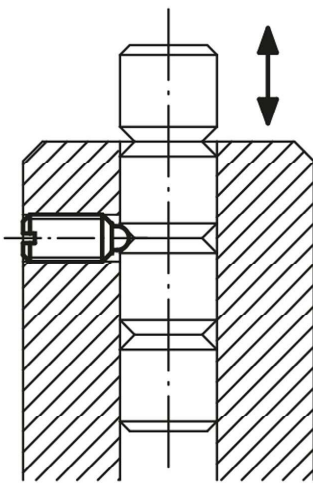

Drawings

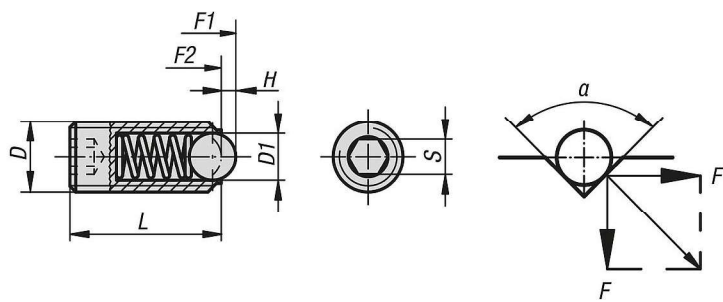

$$\alpha = 60^\circ, F' = 1,732 \times F$$

$$\alpha = 90^\circ, F' = F$$

$$\alpha = 120^\circ, F' = 0,577 \times F$$

Overview of items

Spring plungers with hexagon socket and ball, standard spring

Spring plungers with hexagon socket and ball, steel

Overview of items

Order No.	D	D1	H	L	S	Spring force initial pressure F1 approx. N	Spring force final pressure F2 approx. N
K0315.03	M3	1,5	0,4	9	1,5	1,5	3
K0315.04	M4	2,5	0,8	10	2	4	10
K0315.05	M5	3	0,9	14	2,5	6	11
K0315.06	M6	3,5	1	15	3	9	13
K0315.08	M8	5	1,5	18	4	15	30
K0315.10	M10	6	2	23	5	20	35
K0315.12	M12	8	2,5	26	6	30	55
K0315.16	M16	10	3,5	33	8	65	125
K0315.20	M20	12	4,5	43	10	80	160
K0315.24	M24	15	5,5	48	12	90	180

Spring plungers with hexagon socket and ball, reinforced spring

Order No.	D	D1	H	L	S	Spring force initial pressure F1 approx. N	Spring force final pressure F2 approx. N
K0315.203	M3	1,5	0,4	9	1,5	5	7
K0315.204	M4	2,5	0,8	10	2	12	22
K0315.205	M5	3	0,9	14	2,5	19	30
K0315.206	M6	3,5	1	15	3	28	40
K0315.208	M8	5	1,5	18	4	47	73
K0315.210	M10	6	2	23	5	66	100
K0315.212	M12	8	2,5	26	6	66	120
K0315.216	M16	10	3,5	33	8	90	180
K0315.220	M20	12	4,5	43	10	115	240
K0315.224	M24	15	5,5	48	12	130	270

Spring plungers with hexagon socket and ball, long version, standard spring

Order No.	D	D1	H	L	S	Spring force initial pressure F1 approx. N	Spring force final pressure F2 approx. N
K0315.404	M4	2,5	0,8	16	2	4	10
K0315.405	M5	3	0,9	20	2,5	6	11
K0315.406	M6	3,5	1	25	3	9	13
K0315.408	M8	5	1,5	30	4	15	30
K0315.410	M10	6	2	35	5	20	35
K0315.412	M12	8	2,5	40	6	30	55
K0315.416	M16	10	3,5	45	8	65	125