

# Indexing plungers short version

## Item description/product images

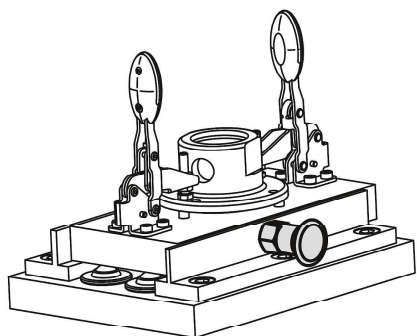
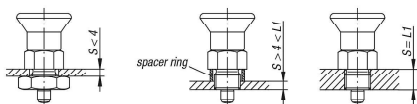

### Description

**Material:**

Steel version  
Indexing pin hardened:  
grade 5.8

Stainless steel version  
Indexing pin not hardened:  
Threaded sleeve 1.4305.  
Indexing pin 1.4305.

Mushroom knob black-grey thermoplastic.

**Version:**

Steel version:  
Indexing pin hardened, ground, black oxidised.

Stainless steel version:  
Indexing pin not hardened, ground, bright.

**Note:**

Indexing plungers are used to prevent any change in position due to lateral forces. A new locking position can only be set after the pin has been manually disengaged. Form C or D is recommended for applications in which the pin is disengaged over extended periods and should be prevented from springing back.

**On request:**

Special versions.

## Drawings

Form A  
non-lockout type  
without locknut

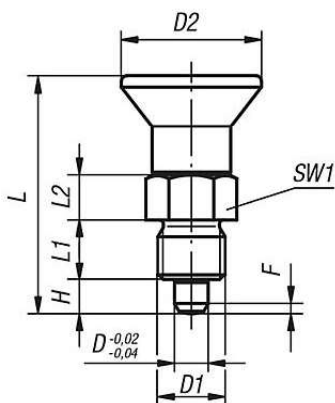

Form B  
non-lockout type  
with locknut

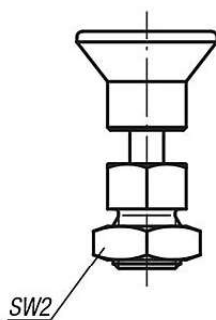

Form C  
lockout type  
without locknut

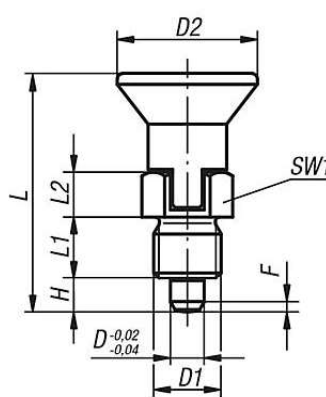

Form D  
lockout type  
with locknut

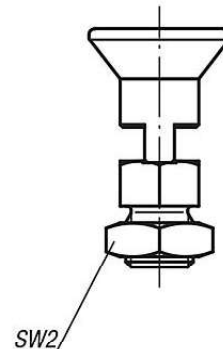

## Overview of items

Indexing plungers, short version, steel, indexing pin hardened

## Indexing plungers short version

### Overview of items

Order No. Form A	Order No. Form B	Order No. Form C	Order No. Form D	D	D1	D2	L	L1	L2	Travel S	SW1	SW2	Fx30°	Spring force initial pressure F1 approx. N	Spring force final pressure F2 approx. N
K0631.5903	K0631.6903	K0631.7903	K0631.8903	3	M6x0,75	14	25,5	6	5	3,5	8	-/10-/10	0,8	4	10
K0631.5004	K0631.6004	K0631.7004	K0631.8004	4	M8x1	18	29,5	6	6	4	10	-/13-/13	1	4	12
K0631.5105	K0631.6105	K0631.7105	K0631.8105	5	M10x1	21	34,5	8	7	5	13	-/17-/17	1,3	5	12
K0631.5206	K0631.6206	K0631.7206	K0631.8206	6	M12x1,5	25	41,7	10	8	6	14	-/19-/19	1,8	6	14
K0631.5308	K0631.6308	K0631.7308	K0631.8308	8	M16x1,5	33	54	12	10	8	19	-/24-/24	2,3	14	28
K0631.5410	K0631.6410	K0631.7410	K0631.8410	10	M20x1,5	33	61	15	12	10	22	-/30-/30	2,8	15	32

### Indexing plungers, short version, stainless steel, indexing pin not hardened

Order No. Form A	Order No. Form B	Order No. Form C	Order No. Form D	D	D1	D2	L	L1	L2	Travel S	SW1	SW2	Fx30°	Spring force initial pressure F1 approx. N	Spring force final pressure F2 approx. N
K0631.15903	K0631.16903	K0631.17903	K0631.18903	3	M6x0,75	14	25,5	6	5	3,5	8	-/10-/10	0,8	4	10
K0631.15004	K0631.16004	K0631.17004	K0631.18004	4	M8x1	18	29,5	6	6	4	10	-/13-/13	1	4	12
K0631.15105	K0631.16105	K0631.17105	K0631.18105	5	M10x1	21	34,5	8	7	5	13	-/17-/17	1,3	5	12
K0631.15206	K0631.16206	K0631.17206	K0631.18206	6	M12x1,5	25	41,7	10	8	6	14	-/19-/19	1,8	6	14
K0631.15308	K0631.16308	K0631.17308	K0631.18308	8	M16x1,5	33	54	12	10	8	19	-/24-/24	2,3	14	28
K0631.15410	K0631.16410	K0631.17410	K0631.18410	10	M20x1,5	33	61	15	12	10	22	-/30-/30	2,8	15	32