

Indexing plungers with thread lock

Item description/product images



Description

Material:

Steel version:
thread and indexing pin free-cutting steel

Stainless steel version:
threaded sleeve 1.4305
indexing pin 1.4034.

Mushroom knob black grey thermoplastic.

Thread lock blue polyamide.

Version:

Steel version:
indexing pin hardened, ground and black oxidised.

Stainless steel version:
indexing pin hardened, ground and bright.

Note:

Indexing plungers are used to prevent any change in locking position due to lateral forces. A new locking position can only be set after the pin has been manually disengaged. Form CP is recommended for applications where the plunger remains disengaged over a long period and the pin should be prevented from springing back. The screw lock allows the plunger to be screwed in to the exact depth required, no spacer ring is required.

The screw lock is a spotted-on polyamide coating that grips the screw flank.

On request:

Special versions.

Drawings

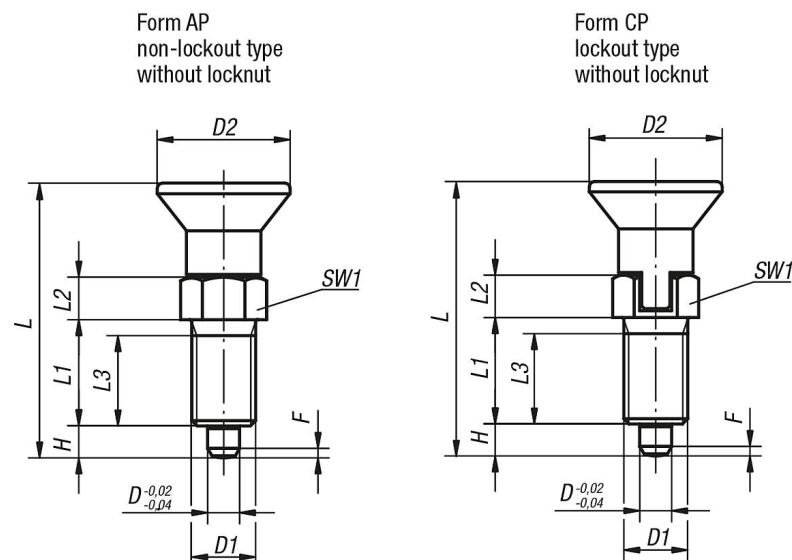

Indexing plungers with thread lock

Overview of items

Steel, indexing pin hardened

Order No. Form AP	Order No. Form CP	D	D1	D2	L	L1	L2	L3	H	SW1	Fx30°	Spring force initial pressure F1 approx. N	Spring force final pressure F2 approx. N
K1096.91903	K1096.93903	3	M6x0,75	14	31,5	12	5	10	3,5	8	0,8	4,5	10
K1096.91004	K1096.93004	4	M8x1	18	38,5	15	6	13	4	10	1	6	12
K1096.91105	K1096.93105	5	M10x1	21	43,5	17	7	15	5	13	1,3	5	12
K1096.91206	K1096.93206	6	M12x1,5	25	51,7	20	8	17	6	14	1,8	6	14
K1096.91308	K1096.93308	8	M16x1,5	33	68	26	10	23	8	19	2,3	15	35
K1096.91410	K1096.93410	10	M20x1,5	33	74	28	12	25	10	22	2,8	15	34
K1096.91412	K1096.93412	12	M20x1,5	33	78	28	14	25	12	22	2,8	15	39
K1096.91516	K1096.93516	16	M24x2	40	96	32	18	28	16	27	3,2	20	46

Stainless steel, indexing pin hardened

Order No. Form AP	Order No. Form CP	D	D1	D2	L	L1	L2	L3	H	SW1	Fx30°	Spring force initial pressure F1 approx. N	Spring force final pressure F2 approx. N
K1096.091903	K1096.093903	3	M6x0,75	14	31,5	12	5	10	3,5	8	0,8	4,5	10
K1096.091004	K1096.093004	4	M8x1	18	38,5	15	6	13	4	10	1	6	12
K1096.091105	K1096.093105	5	M10x1	21	43,5	17	7	15	5	13	1,3	5	12
K1096.091206	K1096.093206	6	M12x1,5	25	51,7	20	8	17	6	14	1,8	6	14
K1096.091308	K1096.093308	8	M16x1,5	33	68	26	10	23	8	19	2,3	15	35
K1096.091410	K1096.093410	10	M20x1,5	33	74	28	12	25	10	22	2,8	15	34
K1096.091412	K1096.093412	12	M20x1,5	33	78	28	14	25	12	22	2,8	15	39
K1096.091516	K1096.093516	16	M24x2	40	96	32	18	28	16	27	3,2	20	46