

## No. 907Q

### TORX key with T-grip

Blade: CHROME-VANADIUM, hardened and **chromium-plated** with black tip.

Grip: impact-resistant plastic (cadmium-free), green.



Order no.	TORX	A	B	L	L1	Weight [g]
45906	T 9	2,50	80	125	100	35
45914	T10	2,74	80	125	100	35
45922	T15	3,27	80	125	100	36
45930	T20	3,86	100	125	100	60
45948	T25	4,43	100	125	100	60
45955	T27	4,99	100	131	100	70
45963	T30	5,52	100	131	100	75
45989	T40	6,65	100	131	100	80
46029	T50	8,83	120	188	150	160

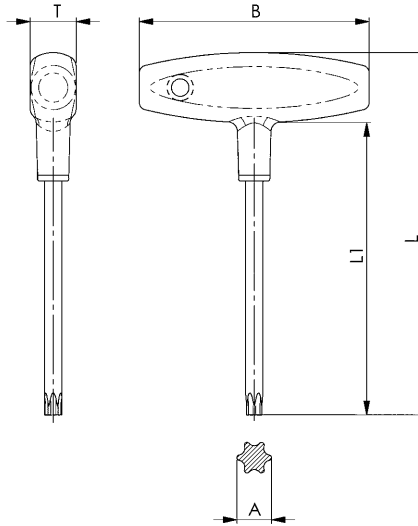

### Recommendations



No. 906QE,  
page 10



No. 906QZ,  
page 32

## No. 907Q-WT7

### TORX workshop stand

with T-grip TORX key no. 907Q, 7-piece set.

Blades: CHROME-VANADIUM, hardened and **chromium-plated** with black tip.

Grip: impact-resistant plastic (cadmium-free), green.

Stand: single-grade, impact-resistant **plastic** with clips for connecting further workshop stands.



Order no.	Contents: TORX x blade length L1	Weight [g]
46722	T10x100, T15x100, T20x100, T25x100, T30x100, T40x100, T50x150	660

### Recommendations



No. 906-WM9,  
page 13



Space for two additional TORX keys

Subject to technical alterations.