

Spring plungers with hexagon socket and thrust pin, LONG-LOK secured, stainless steel

Item description/product images



Description

Material:

Sleeve 1.4305.
Thrust pin 1.4034.
Spring 1.4310.

LONG-LOK thread lock Nylon.

Version:

Bright.
Thrust pin hardened.

Drawing reference:

L2 = ca. two full threads

1) grub screw glued-in

Drawings

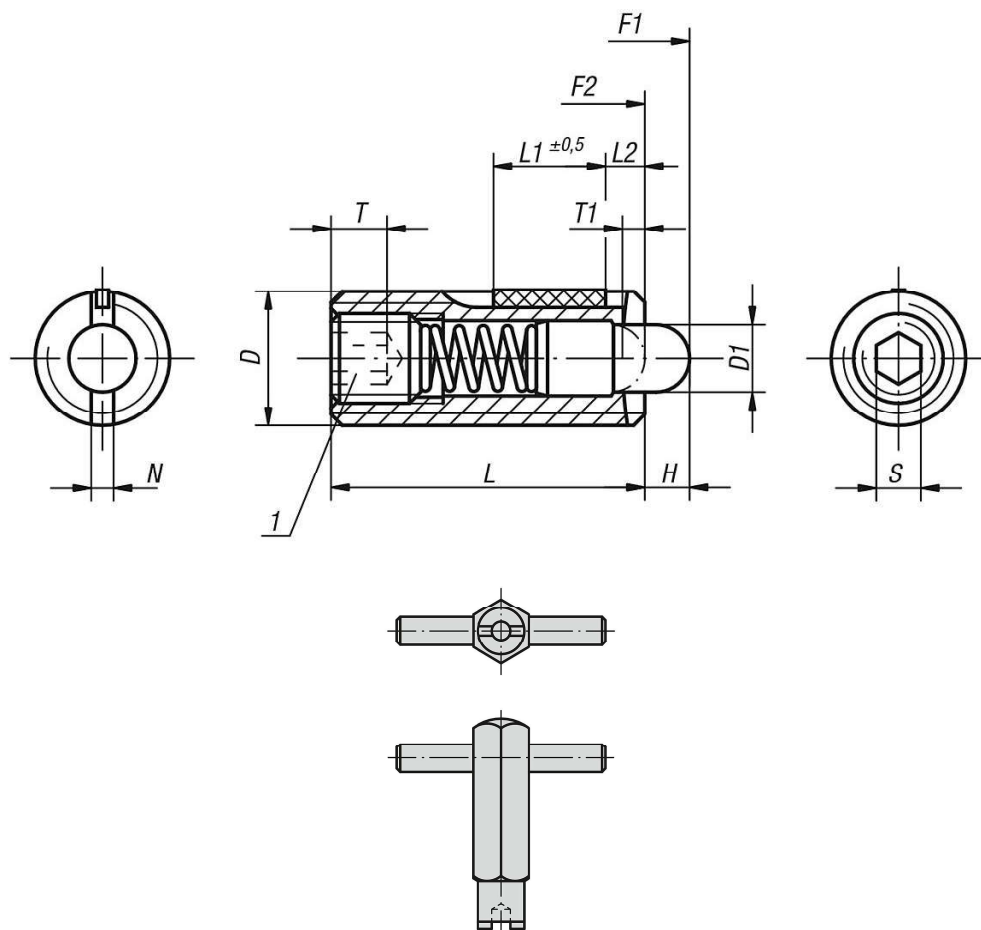

Overview of items

Spring plungers with hexagon socket and thrust pin, LONG-LOK secured, stainless steel

Overview of items

Spring plungers with hexagon socket and thrust pin, standard spring force, LONG-LOK secured

Order No.	D	D1	H	L	L1	T	T1	N	S	Spring force initial pressure F1 approx. N	Spring force final pressure F2 approx. N	Tightening torque approx. Nm	Loosening torque approx. Nm	Order No. assembly key
K0329.05	M5	2,4	2,3	18	7	2	0,8	0,8	1,5	5	17	0,12	0,08	K0317.905
K0329.06	M6	2,7	2,5	20	7	2,5	1	1	2	6	17	0,45	0,22	K0317.906
K0329.08	M8	3,5	3	22	8	3	1,4	1,2	2,5	7	29	1,05	0,37	K0317.908
K0329.10	M10	4	3	22	9	3,5	1,4	1,6	3	8	31	1,3	0,6	K0317.910
K0329.12	M12	6	4	28	10	5	2	2	4	10	47	2	1,3	K0317.912
K0329.16	M16	7,5	5	32	14	6	2,5	2,5	5	38	85	3,9	3	K0317.916

Spring plungers with hexagon socket and thrust pin, reinforced spring force, LONG-LOK secured

Order No.	D	D1	H	L	L1	T	T1	N	S	Spring force initial pressure F1 approx. N	Spring force final pressure F2 approx. N	Tightening torque approx. Nm	Loosening torque approx. Nm	Order No. assembly key
K0329.205	M5	2,4	2,3	18	7	2	0,8	0,8	1,5	9	26	0,12	0,08	K0317.905
K0329.206	M6	2,7	2,5	20	7	2,5	1	1	2	11	35	0,45	0,22	K0317.906
K0329.208	M8	3,5	3	22	8	3	1,4	1,2	2,5	15	48	1,05	0,37	K0317.908
K0329.210	M10	4	3	22	9	3,5	1,4	1,6	3	15	58	1,3	0,6	K0317.910
K0329.212	M12	6	4	28	10	5	2	2	4	19	74	2	1,3	K0317.912