

Indexing plungers

Item description/product images

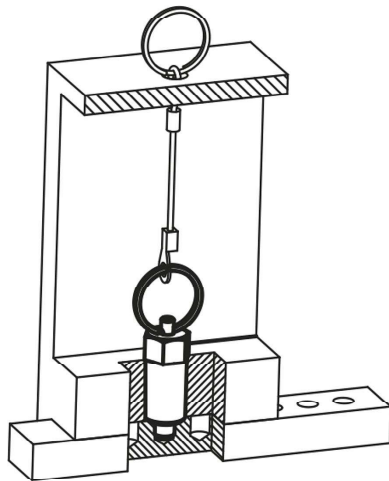

Description

Material:

Steel version

Indexing pin hardened:
grade 5.8.

Stainless steel version

Indexing pin hardened:
Threaded sleeve 1.4305.
Indexing pin 1.4034.

Indexing pin not hardened:

Threaded sleeve 1.4305.
Indexing pin 1.4305.

Key ring 1.4310, bright.

Version:

Steel version:

Indexing pin hardened, ground, black oxidised.

Stainless steel version:

Indexing pin hardened, ground and bright.

Indexing pin not hardened, ground and bright.

Note:

Indexing plungers are used to prevent any change in locking position due to lateral forces. A new locking position can only be set after the pin has been disengaged. The key ring is also suitable for automatic actuation of the indexing plunger by e.g. program-controlled pneumatic cylinder or by remote control using bowden cables.

On request:

Special versions.

Indexing plungers

Drawings

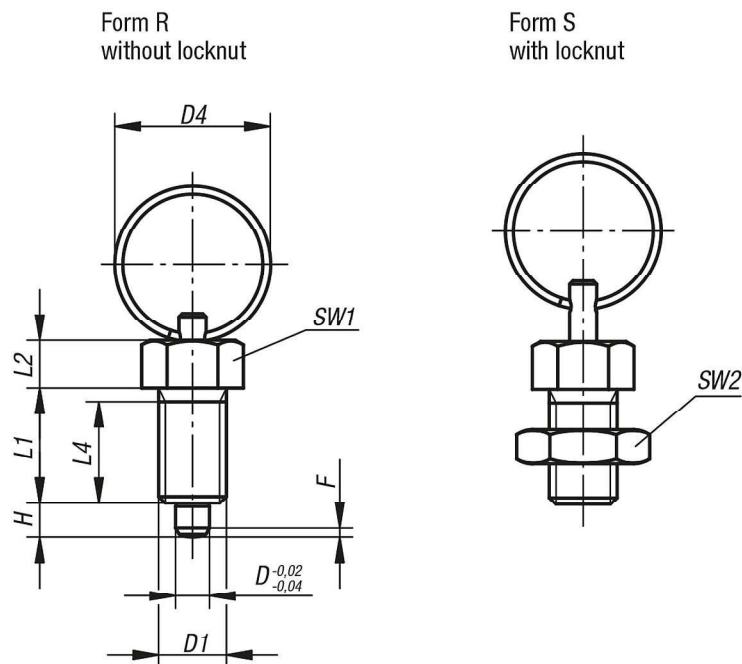

Overview of items

Indexing plungers, steel, indexing pin hardened

Order No. Form R	Order No. Form S	D	D1	D4	L	L1	L2	L4	Travel S	SW1	SW2	Fx30°	Spring force initial pressure F1 approx. N	Spring force final pressure F2 approx. N
K0342.3004	K0342.4004	4	M8x1	15	40	15	6	13	4	10	- / 13	1	6	12
K0342.3105	K0342.4105	5	M10x1	23	52	17	7	15	5	13	- / 17	1,3	5	12
K0342.3206	K0342.4206	6	M12x1,5	23	57	20	8	17	6	14	- / 19	1,8	6	14
K0342.3308	K0342.4308	8	M16x1,5	28	72	26	10	23	8	19	- / 24	2,3	15	35
K0342.3410	K0342.4410	10	M20x1,5	28	78	28	12	25	10	22	- / 30	2,8	15	34

Indexing plungers, stainless steel, indexing pin hardened

Order No. Form R	Order No. Form S	D	D1	D4	L	L1	L2	L4	Travel S	SW1	SW2	Fx30°	Spring force initial pressure F1 approx. N	Spring force final pressure F2 approx. N
K0342.03004	K0342.04004	4	M8x1	15	40	15	6	13	4	10	- / 13	1	6	12
K0342.03105	K0342.04105	5	M10x1	23	52	17	7	15	5	13	- / 17	1,3	5	12
K0342.03206	K0342.04206	6	M12x1,5	23	57	20	8	17	6	14	- / 19	1,8	6	14
K0342.03308	K0342.04308	8	M16x1,5	28	72	26	10	23	8	19	- / 24	2,3	15	35
K0342.03410	K0342.04410	10	M20x1,5	28	78	28	12	25	10	22	- / 30	2,8	15	34

Indexing plungers, stainless steel, indexing pin not hardened

Order No. Form R	Order No. Form S	D	D1	D4	L	L1	L2	L4	Travel S	SW1	SW2	Fx30°	Spring force initial pressure F1 approx. N	Spring force final pressure F2 approx. N
K0342.13004	K0342.14004	4	M8x1	15	40	15	6	13	4	10	- / 13	1	6	12
K0342.13105	K0342.14105	5	M10x1	23	52	17	7	15	5	13	- / 17	1,3	5	12
K0342.13206	K0342.14206	6	M12x1,5	23	57	20	8	17	6	14	- / 19	1,8	6	14
K0342.13308	K0342.14308	8	M16x1,5	28	72	26	10	23	8	19	- / 24	2,3	15	35
K0342.13410	K0342.14410	10	M20x1,5	28	78	28	12	25	10	22	- / 30	2,8	15	34

