

Indexing plungers for thin-walled parts

Item description/product images

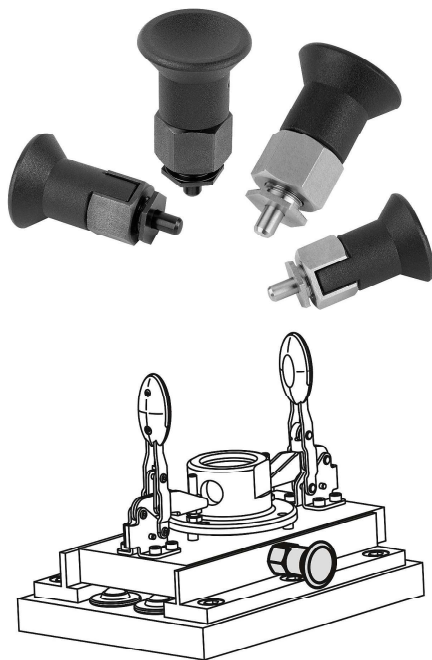

Description

Material:

Steel version
Indexing pin hardened:
grade 5.8

Stainless steel version
Indexing pin not hardened:
Threaded sleeve 1.4305.
Indexing pin 1.4305.

Mushroom knob black-grey thermoplastic.

Version:

Steel version:
Indexing pin hardened, ground, black oxidised.

Stainless steel version:
Indexing pin not hardened, ground, bright.

Note:

These indexing plungers have been specially designed for assembly in thin-walled parts.

Indexing plungers are used where any change in locking position due to lateral forces should be prevented. A new locking position can be set only after the pin has been manually disengaged.

Form C is recommended for applications where the locking pin should remain disengaged for an extended period and be prevented from springing back.

Accessory:

A double-ended ring spanner can be supplied as an accessory to tighten the nut.

Drawings

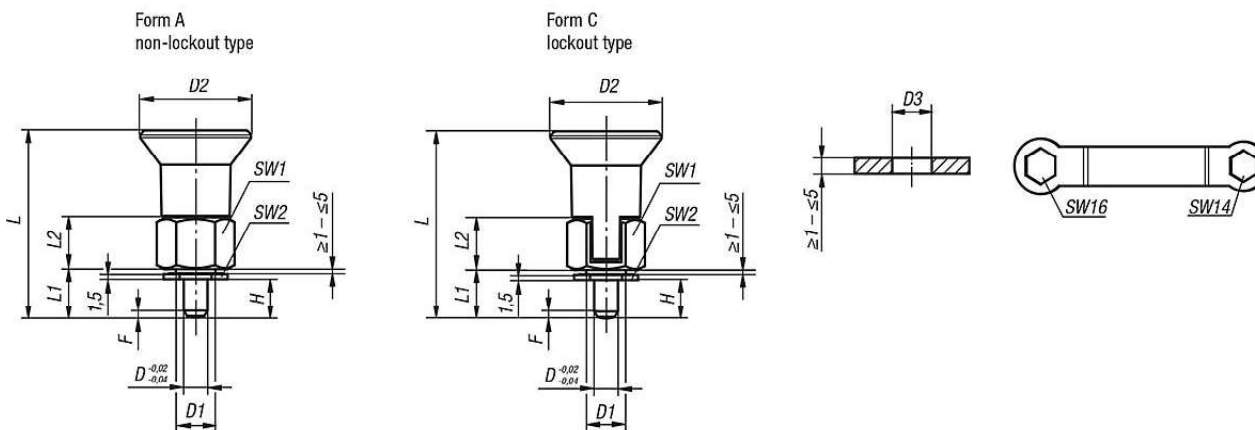

Overview of items

Indexing plungers for thin-walled parts, steel, indexing pin hardened

Indexing plungers for thin-walled parts

Overview of items

Order No.	Form	D	D1	D2	D3	L	L1	L2	H	SW1	SW2	Fx30°	Spring force initial pressure F1 approx. N	Spring force final pressure F2 approx. N	Article number double-ended ring spanner
K0735.31105	A	5	M10x1	28	10	46,5	11,5	13	5-9	17	14	1,3	6	15	K0631.91416
K0735.31206	A	6	M10x1	28	10	47,5	12,5	13	6-10	17	14	1,8	7	19	K0631.91416
K0735.33105	C	5	M10x1	28	10	46,5	11,5	13	5-9	17	14	1,3	6	15	K0631.91416
K0735.33206	C	6	M10x1	28	10	47,5	12,5	13	6-10	17	14	1,8	7	19	K0631.91416

Indexing plungers for thin-walled parts, stainless steel, indexing pin not hardened

Order No.	Form	D	D1	D2	D3	L	L1	L2	H	SW1	SW2	Fx30°	Spring force initial pressure F1 approx. N	Spring force final pressure F2 approx. N	Article number double-ended ring spanner
K0735.311105	A	5	M10x1	28	10	46,5	11,5	13	5-9	17	14	1,3	6	15	K0631.91416
K0735.311206	A	6	M10x1	28	10	47,5	12,5	13	6-10	17	14	1,8	7	19	K0631.91416
K0735.313105	C	5	M10x1	28	10	46,5	11,5	13	5-9	17	14	1,3	6	15	K0631.91416
K0735.313206	C	6	M10x1	28	10	47,5	12,5	13	6-10	17	14	1,8	7	19	K0631.91416

Order No.	Article description
K0631.91416	DOUBLE-ENDED RING SPANNER