

Magnets deep pot NdFeB

Item description/product images



Description

Material:

Housing brass.

Magnetic core NdFeB (neodymium).

Version:

Housing smooth.

Note:

Smooth design, shielded system.

Under no circumstances may Neodym magnets be pressed directly into iron, loss of attractive force due to magnetic short circuits occurs.

Diameter "D" ground to tolerance h6.

The Form A magnets can be shortened by the dimension "H1" with no loss of magnetic force.

Temperature range:

max. 80°C.

Assembly:

The magnets can be mounted by press-fit, screwing-in or gluing.

Drawing reference:

1) magnetic face

Drawings

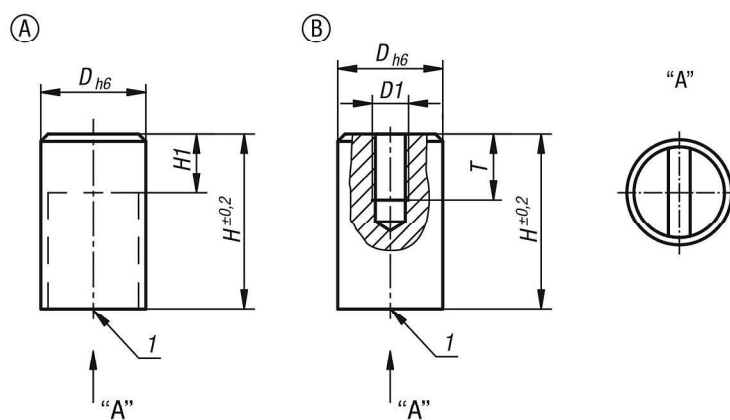

Overview of items

Magnets deep pot NdFeB

Order No.	Form	D	D1	H	H1	T	Magnetic force N	Distance to iron wall mm
K1395.106	A	6	-	20	10	-	10	1,5
K1395.108	A	8	-	20	10	-	25	1,5
K1395.110	A	10	-	20	8	-	45	2

Magnets deep pot NdFeB

Overview of items

Order No.	Form	D	D1	H	H1	T	Magnetic force N	Distance to iron wall mm
K1395.113	A	13	-	20	6	-	70	2,5
K1395.116	A	16	-	20	2	-	150	3
K1395.120	A	20	-	25	5	-	280	4
K1395.125	A	25	-	35	7	-	450	5
K1395.132	A	32	-	40	4,5	-	700	6
K1395.206	B	6	M3	20	-	5	10	1,5
K1395.208	B	8	M3	20	-	5	25	1,5
K1395.210	B	10	M4	20	-	7	45	2
K1395.213	B	13	M4	20	-	7	70	2,5
K1395.216	B	16	M4	25	-	8	150	3
K1395.220	B	20	M6	25	-	6	280	4
K1395.225	B	25	M6	35	-	8	450	5
K1395.232	B	32	M6	40	-	6	700	6