

No. 6826A

Heavy pneumatic toggle clamp

with vertical cylinder attachment.
 Tempered steel, burnished. The bearing bolts running in bearing bushes are tempered, ground and locked with circlips.
 With magnetic piston for end-position monitoring.
 Ready to connect, comprising:
 - mechanical element
 - double acting pneumatic cylinder



Order no.	Size	F1 [kN]	F2 [kN]	F3 [kN]	F4 [kN]	F5 [kN]	Vn [dm ³]	Weight [g]
559772	4	6	9	1,5	2,2	0,75	1,0	3850
559773	6	12	18	2,5	3,5	1,00	1,6	6950
559774	8	20	30	4,0	6,0	1,80	1,8	13160

Application:

These pneumatic toggle clamps are of machine tool quality and can be installed in machines such as material handling lines and special machines. Opening and clamping position of the clamp can be controlled electrically and can be integrated into automated manufacturing.

Note:

Suitable proximity switches for end-position monitoring are available using order no. 392241.
 Design: PUR cable 0.3 m with M8 plug connection and rotating knurled nuts.
 Switching function: NOC.
 Output: PNP.

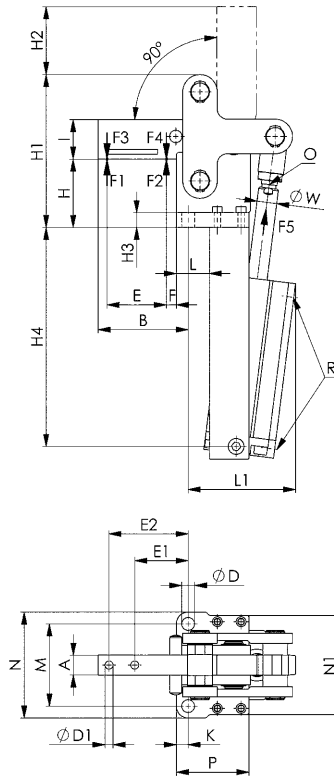

Dimensions:

Order no.	Size	A	B	dia. D	dia. D1	E	E1	E2	F	H	H1	H2	H3	H4
559772	4	15	82	11	6,2	54	47	74	10,0	65	129,5	75,5	12	193
559773	6	20	91	13	8,2	60	54	80	10,0	69	154,5	68,5	15	221
559774	8	30	125	17	13,0	95	67	107	9,5	94	204,0	110,0	20	255

Order no.	Size	I	K	L	L1	M	N	N1	O	P	R	dia. W	Piston dia.
559772	4	30	10	37,0	103	70	90	82	M12 x 1,25	67,0	G1/8	16	40
559773	6	40	12	33,5	120	83	107	100	M16 x 1,50	73,5	G1/4	20	50
559774	8	60	15	49,0	162	115	145	115	M16 x 1,50	109,0	G1/4	20	63

Subject to technical alterations.