

No. 6829KR/KL

Swing clamp, pneumatic, flange-mounting version

double-acting

For recessed installation in fixtures. Both compressed-air connections are in the flange. Piston rod non-rusting, polished. Body is made of aluminium, anodised. HART-COAT® surface for wear-resistance. Including screw and spring washer for simple setting of the clamp arm position.

Mounting:

- from above with cap screws through the flange
- from below in a bore in the fixture using grooved nuts and clamping against the flange
- from above with grooved nuts against the fixture

Accessories (not included in pack):

- Clamping arm 6829SP
- Grooved nut 6829N
- Clamping screw 6880



CAD



Order no.	Size	right swinging	left swinging	F3 [kN]	Connecting thread for clamping screws	Weight [g]
560012	12	●	-	0,03	M4	130
560018	12	-	●	0,03	M4	130
560011	16	●	-	0,06	M4	180
560019	16	-	●	0,06	M4	180
560010	20	●	-	0,08	M6	300
560020	20	-	●	0,08	M6	300
93484	25	●	-	0,17	M6	500
93559	25	-	●	0,17	M6	500
93492	32	●	-	0,27	M8	650
93567	32	-	●	0,27	M8	650
93500	40	●	-	0,45	M8	800
93575	40	-	●	0,45	M8	800
93518	50	●	-	0,70	M12	920
93583	50	-	●	0,70	M12	920
93526	63	●	-	1,10	M12	1080
93591	63	-	●	1,10	M12	1080

F3 = at 6 bar max. air pressure

Note:

The mounting holes in the flange are the same as in threaded flange no. 6828GF. Operate only with lubricated air.

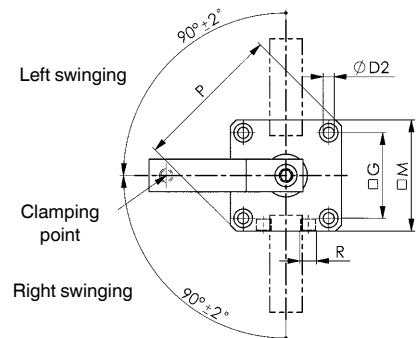
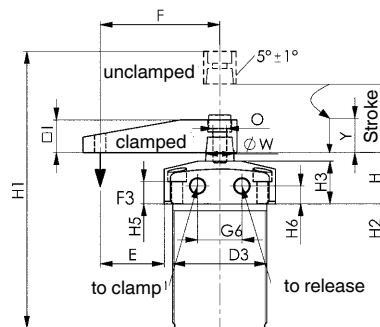

Examples of mountings:

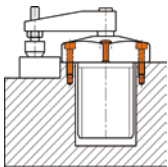

with 4 cap screws from above

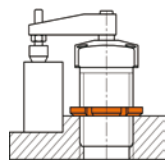

with grooved nut from above

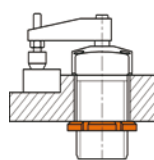

with grooved nut from below

Recommendations



No. 6829SP,
page 151



No. 6829N,
page 152



No. 6829GF,
page 152

Dimensions:

Order no.	Size	dia. D2	D3	E	F	G	G6	H	H1	H2	H3	H5	H6	I	M	O	P	R	dia. W	Piston dia.	Y Clamping stroke*	Stroke
560012	12	4,5	M25x1,5	18,7	35	23,0	10	25	105	50	20	11	9,0	12,0	33	M5	43	M5	8	12	8,6	17,6
560018	12	4,5	M25x1,5	18,7	35	23,0	10	25	105	50	20	11	9,0	12,0	33	M5	43	M5	8	12	8,6	17,6
560011	16	4,5	M30x1,5	23,0	41	26,5	12	25	105	50	20	11	9,0	12,0	36	M5	47	M5	8	16	8,5	17,5
560019	16	4,5	M30x1,5	23,0	41	26,5	12	25	105	50	20	11	9,0	12,0	36	M5	47	M5	8	16	8,5	17,5
560010	20	4,5	M35x1,5	27,5	48	30,5	14	26	107	65	20	10	9,0	16,0	41	M8	54	M5	12	20	15,0	27,0
560020	20	4,5	M35x1,5	27,5	48	30,5	14	26	107	65	20	10	9,0	16,0	41	M8	54	M5	12	20	15,0	27,0
93484	25	5,5	M40x1,5	25,0	50	37,0	23	30	135	62	25	15	11,5	16,0	50	M8	66	M5	14	25	13,0	26,0
93559	25	5,5	M40x1,5	25,0	50	37,0	23	30	135	62	25	15	11,5	16,0	50	M8	66	M5	14	25	13,0	26,0
93492	32	6,5	M50x1,5	30,0	60	45,0	23	30	152	73	25	13	10,5	19,0	60	M8	80	G1/8	16	32	14,0	28,0
93567	32	6,5	M50x1,5	30,0	60	45,0	23	30	152	73	25	13	10,5	19,0	60	M8	80	G1/8	16	32	14,0	28,0
93500	40	6,5	M55x1,5	37,5	70	50,0	26	30	152	73	25	13	10,5	19,0	65	M8	87	G1/8	16	40	16,0	30,0
93575	40	6,5	M55x1,5	37,5	70	50,0	26	30	152	73	25	13	10,5	19,0	65	M8	87	G1/8	16	40	16,0	30,0
93518	50	8,5	M65x1,5	42,5	80	58,0	32	30	164	80	25	11	10,5	25,5	75	M10	100	G1/8	20	50	16,0	32,0
93583	50	8,5	M65x1,5	42,5	80	58,0	32	30	164	80	25	11	10,5	25,5	75	M10	100	G1/8	20	50	16,0	32,0
93526	63	8,5	M80x1,5	45,0	90	70,0	35	30	164	80	25	11	10,5	25,5	90	M10	118	G1/8	20	63	14,0	30,0
93591	63	8,5	M80x1,5	45,0	90	70,0	35	30	164	80	25	11	10,5	25,5	90	M10	118	G1/8	20	63	14,0	30,0

* Swing clamps may only be loaded during the clamping stroke Y.

Subject to technical alterations.