

Power clamp

Item description/product images



Description

Material:

Carbon steel.

Version:

Forged, black electro zinc-plated.

Note:

We recommend using a lubricating paste to reduce wear to the adjustment screw. Risers are available to increase the height of the power clamp.

Supplied with clamping element, support element, DIN 508 slot key and grade 12.9 bolt.

Application:

The height of the clamping arm can be infinitely adjusted using the adjustment screw and the workpiece can then be clamped.

Advantages:

- Very high retaining forces of 30–49 kN.
- Low height.
- Simple element assembly.
- Enables very fast, simple clamping.
- Infinitely adjustable height and length.
- Use in 14-28 mm T-slots or M12, M16, M20 grid systems.
- Thrust pad available in smooth and serrated versions.

Accessory:

Raiser K1206

Thrust pads K1215

Drawings

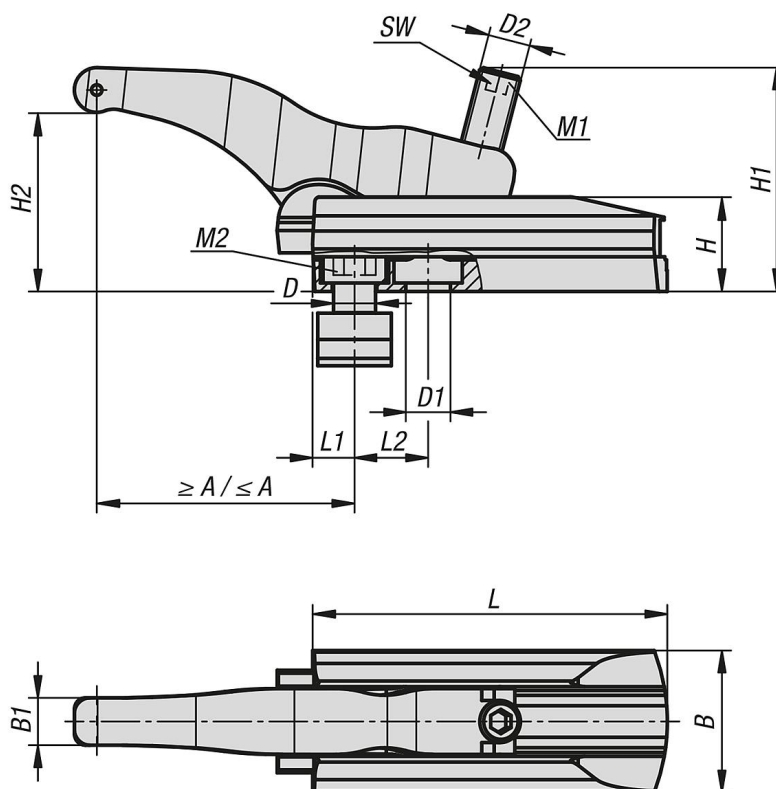

Overview of items

Power clamp

Order No.	Version 1	H2	A min.	A max.	B	B1	Slot width	D	D1	D2	H	H1	L	L1	L2	SW	Clamping force kN	Tightening torque M1 Nm	Tightening torque M2 Nm
K1205.112135	long	6-68	13	110	54	18	14	M12	13	M16	36	85	135	13	25	8	30	100	70
K1205.116135	long	6-68	16	114	54	18	18	M16	17	M16	36	85	135	16	28	8	30	100	150
K1205.116155	long	5-80	16	134	60	20	18	M16	17	M20	42	105	155	16	32	10	43	220	150
K1205.120175	long	7-88	19	165	75	25	22	M20	21	M24	52	125	175	19	36	12	49	220	200
K1205.212095	short	6-50	12	82	54	18	14	M12	13	M16	36	78	95	12	20	8	32	120	70
K1205.216110	short	6-50	15	95	60	20	18	M16	17	M20	42	92	110	15	26	10	40	150	150