

## UNI lock clamping pin system size 50 mm

### Item description/product images



### Description

**Material:**

Rust resistant tool steel.

**Version:**

Contact faces hardened and ground.

**Note:**

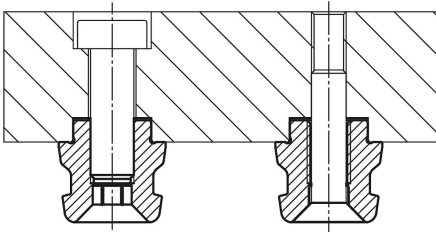

The UNI lock clamping pin is suitable for clamping and positioning workpieces and fixtures. Clamping pins are screwed onto the exchange element and adapted to the various basic modules.

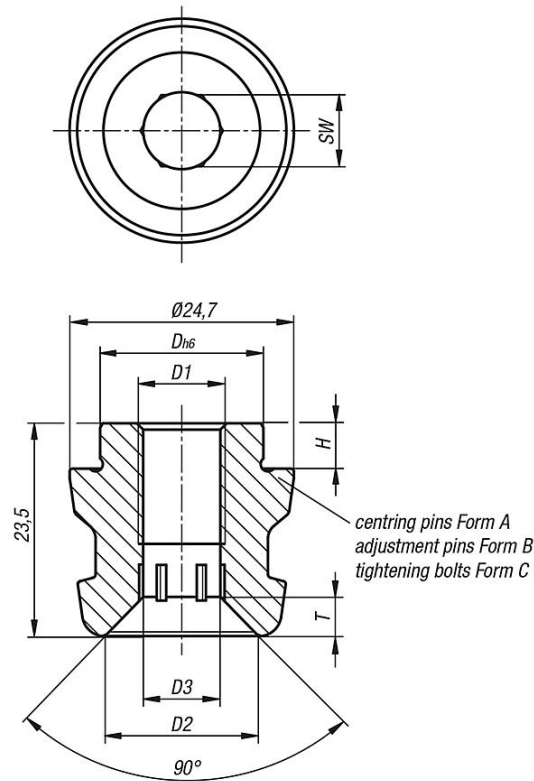

## UNI lock clamping pin system size 50 mm

### Drawings



-  Centring pins = Form A      fixes in x and y axis (reference point)
-  Adjustment pins = Form B      fixes the free axis (bayonet pin)
-  Tightening bolts = Form C      Pins with undersize (no centring function, clamping only)

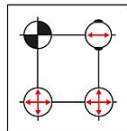

### Overview of items

#### UNI lock clamping pin, system size 50 mm

Order No.	Form	D1	D	D2	D3	H	T	SW
K1121.125180510	A	M10	18	16,5	9	5	5	8
K1121.225180510	B	M10	18	16,5	9	5	5	8
K1121.325180510	C	M10	18	16,5	9	5	5	8