

# Cam levers internal and external thread, stainless steel

## Item description/product images



## Description

### Material:

Handles 1.4308 stainless steel.  
Thrust washer plastic PA 66 GF 35-X, fibreglass reinforced.  
Hinge pin, washer and screw 1.4305 stainless steel.

### Version:

Handle electropolished or blasted.  
Thrust washer black.  
Hinge pin, washer and screw bright.

### Note:

Plastics are subject to creeping under load (retardation).

## Drawings

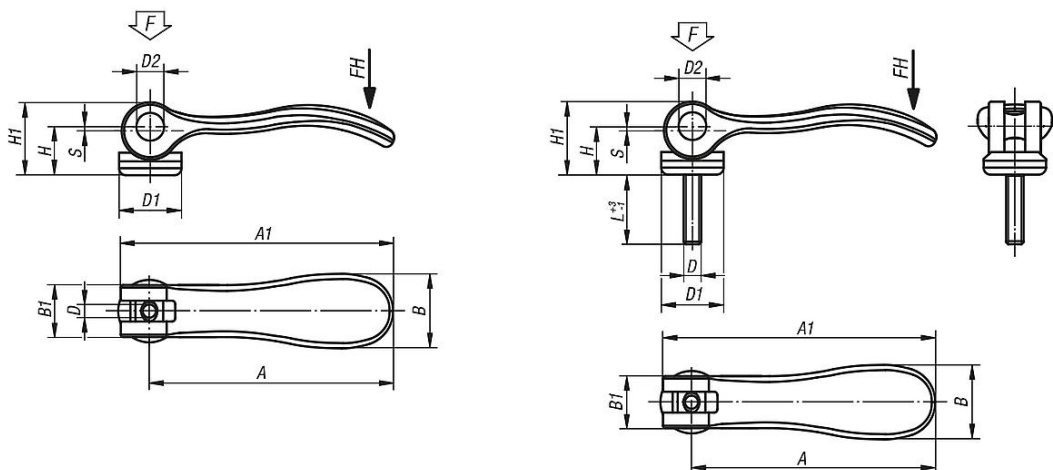

## Overview of items

### Cam levers with internal thread, stainless steel

Order No.	Surface finish body	D	D1	D2	B	B1	H	H1	A	A1	L	Travel S	Clamping force F (kN)	Hand force FH N
K0645.9512003	electropolished	M3	12	6	14,4	11,5	9	13	36,2	41,7	-	1	1,5	90
K0645.9512004	electropolished	M4	12	6	14,4	11,5	9	13	36,2	41,7	-	1	1,5	90
K0645.0512004	electropolished	M4	15,4	8	18	13	11,2	17	52,3	59,1	-	1	2,5	100
K0645.0512005	electropolished	M5	15,4	8	18	13	11,2	17	52,3	59,1	-	1	2,5	100
K0645.1512005	electropolished	M5	18,1	9	21,5	15	14,5	22	70,4	79,2	-	1,2	4	120
K0645.1512006	electropolished	M6	18,1	9	21,5	15	14,5	22	70,4	79,2	-	1,2	4	120
K0645.2512008	electropolished	M8	27,1	11	33,3	24	18	28,5	96	108	-	1,5	8	350
K0645.9512303	blasted	M3	12	6	14,4	11,5	9	13	36,2	41,7	-	1	1,5	90
K0645.9512304	blasted	M4	12	6	14,4	11,5	9	13	36,2	41,7	-	1	1,5	90
K0645.0512304	blasted	M4	15,4	8	18	13	11,2	17	52,3	59,1	-	1	2,5	100
K0645.0512305	blasted	M5	15,4	8	18	13	11,2	17	52,3	59,1	-	1	2,5	100
K0645.1512305	blasted	M5	18,1	9	21,5	15	14,5	22	70,4	79,2	-	1,2	4	120
K0645.1512306	blasted	M6	18,1	9	21,5	15	14,5	22	70,4	79,2	-	1,2	4	120
K0645.2512308	blasted	M8	27,1	11	33,3	24	18	28,5	96	108	-	1,5	8	350
K0645.9512003X10	electropolished	M3	12	6	14,4	11,5	9	13	36,2	41,7	10	1	1,5	90

## Cam levers internal and external thread, stainless steel

### Overview of items

Order No.	Surface finish body	D	D1	D2	B	B1	H	H1	A	A1	L	Travel S	Clamping force F (kN)	Hand force FH N
K0645.9512003X15	electropolished	M3	12	6	14,4	11,5	9	13	36,2	41,7	15	1	1,5	90
K0645.9512003X30	electropolished	M3	12	6	14,4	11,5	9	13	36,2	41,7	30	1	1,5	90
K0645.9512004X10	electropolished	M4	12	6	14,4	11,5	9	13	36,2	41,7	10	1	1,5	90
K0645.9512004X15	electropolished	M4	12	6	14,4	11,5	9	13	36,2	41,7	15	1	1,5	90
K0645.9512004X30	electropolished	M4	12	6	14,4	11,5	9	13	36,2	41,7	30	1	1,5	90
K0645.0512004X15	electropolished	M4	15,4	8	18	13	11,2	17	52,3	59,1	15	1	2,5	100
K0645.0512004X20	electropolished	M4	15,4	8	18	13	11,2	17	52,3	59,1	20	1	2,5	100
K0645.0512004X30	electropolished	M4	15,4	8	18	13	11,2	17	52,3	59,1	30	1	2,5	100
K0645.0512005X20	electropolished	M5	15,4	8	18	13	11,2	17	52,3	59,1	20	1	2,5	100
K0645.0512005X30	electropolished	M5	15,4	8	18	13	11,2	17	52,3	59,1	30	1	2,5	100
K0645.0512005X40	electropolished	M5	15,4	8	18	13	11,2	17	52,3	59,1	40	1	2,5	100
K0645.0512005X50	electropolished	M5	15,4	8	18	13	11,2	17	52,3	59,1	50	1	2,5	100
K0645.1512005X20	electropolished	M5	18,1	9	21,5	15	14,5	22	70,4	79,2	20	1,2	4	120
K0645.1512005X30	electropolished	M5	18,1	9	21,5	15	14,5	22	70,4	79,2	30	1,2	4	120
K0645.1512005X40	electropolished	M5	18,1	9	21,5	15	14,5	22	70,4	79,2	40	1,2	4	120
K0645.1512005X50	electropolished	M5	18,1	9	21,5	15	14,5	22	70,4	79,2	50	1,2	4	120
K0645.1512006X20	electropolished	M6	18,1	9	21,5	15	14,5	22	70,4	79,2	20	1,2	4	120
K0645.1512006X30	electropolished	M6	18,1	9	21,5	15	14,5	22	70,4	79,2	30	1,2	4	120
K0645.1512006X40	electropolished	M6	18,1	9	21,5	15	14,5	22	70,4	79,2	40	1,2	4	120
K0645.1512006X50	electropolished	M6	18,1	9	21,5	15	14,5	22	70,4	79,2	50	1,2	4	120
K0645.2512008X25	electropolished	M8	27,1	11	33,3	24	18	28,5	96	108	25	1,5	8	350
K0645.2512008X30	electropolished	M8	27,1	11	33,3	24	18	28,5	96	108	30	1,5	8	350
K0645.2512008X40	electropolished	M8	27,1	11	33,3	24	18	28,5	96	108	40	1,5	8	350
K0645.2512008X50	electropolished	M8	27,1	11	33,3	24	18	28,5	96	108	50	1,5	8	350
K0645.2512010X25	electropolished	M10	27,1	11	33,3	24	18	28,5	96	108	25	1,5	8	350
K0645.2512010X30	electropolished	M10	27,1	11	33,3	24	18	28,5	96	108	30	1,5	8	350
K0645.2512010X40	electropolished	M10	27,1	11	33,3	24	18	28,5	96	108	40	1,5	8	350
K0645.2512010X50	electropolished	M10	27,1	11	33,3	24	18	28,5	96	108	50	1,5	8	350
K0645.9512303X10	blasted	M3	12	6	14,4	11,5	9	13	36,2	41,7	10	1	1,5	90
K0645.9512303X15	blasted	M3	12	6	14,4	11,5	9	13	36,2	41,7	15	1	1,5	90
K0645.9512303X30	blasted	M3	12	6	14,4	11,5	9	13	36,2	41,7	30	1	1,5	90
K0645.9512304X10	blasted	M4	12	6	14,4	11,5	9	13	36,2	41,7	10	1	1,5	90
K0645.9512304X15	blasted	M4	12	6	14,4	11,5	9	13	36,2	41,7	15	1	1,5	90
K0645.9512304X30	blasted	M4	12	6	14,4	11,5	9	13	36,2	41,7	30	1	1,5	90
K0645.0512304X15	blasted	M4	15,4	8	18	13	11,2	17	52,3	59,1	15	1	2,5	100
K0645.0512304X20	blasted	M4	15,4	8	18	13	11,2	17	52,3	59,1	20	1	2,5	100
K0645.0512304X30	blasted	M4	15,4	8	18	13	11,2	17	52,3	59,1	30	1	2,5	100
K0645.0512305X20	blasted	M5	15,4	8	18	13	11,2	17	52,3	59,1	20	1	2,5	100
K0645.0512305X30	blasted	M5	15,4	8	18	13	11,2	17	52,3	59,1	30	1	2,5	100
K0645.0512305X40	blasted	M5	15,4	8	18	13	11,2	17	52,3	59,1	40	1	2,5	100
K0645.0512305X50	blasted	M5	15,4	8	18	13	11,2	17	52,3	59,1	50	1	2,5	100
K0645.1512305X20	blasted	M5	18,1	9	21,5	15	14,5	22	70,4	79,2	20	1,2	4	120
K0645.1512305X30	blasted	M5	18,1	9	21,5	15	14,5	22	70,4	79,2	30	1,2	4	120
K0645.1512305X40	blasted	M5	18,1	9	21,5	15	14,5	22	70,4	79,2	40	1,2	4	120
K0645.1512305X50	blasted	M5	18,1	9	21,5	15	14,5	22	70,4	79,2	50	1,2	4	120
K0645.1512306X20	blasted	M6	18,1	9	21,5	15	14,5	22	70,4	79,2	20	1,2	4	120
K0645.1512306X30	blasted	M6	18,1	9	21,5	15	14,5	22	70,4	79,2	30	1,2	4	120
K0645.1512306X40	blasted	M6	18,1	9	21,5	15	14,5	22	70,4	79,2	40	1,2	4	120
K0645.1512306X50	blasted	M6	18,1	9	21,5	15	14,5	22	70,4	79,2	50	1,2	4	120
K0645.2512308X25	blasted	M8	27,1	11	33,3	24	18	28,5	96	108	25	1,5	8	350
K0645.2512308X30	blasted	M8	27,1	11	33,3	24	18	28,5	96	108	30	1,5	8	350
K0645.2512308X40	blasted	M8	27,1	11	33,3	24	18	28,5	96	108	40	1,5	8	350
K0645.2512308X50	blasted	M8	27,1	11	33,3	24	18	28,5	96	108	50	1,5	8	350
K0645.2512310X25	blasted	M10	27,1	11	33,3	24	18	28,5	96	108	25	1,5	8	350
K0645.2512310X30	blasted	M10	27,1	11	33,3	24	18	28,5	96	108	30	1,5	8	350
K0645.2512310X40	blasted	M10	27,1	11	33,3	24	18	28,5	96	108	40	1,5	8	350
K0645.2512310X50	blasted	M10	27,1	11	33,3	24	18	28,5	96	108	50	1,5	8	350

