

Handwheels

Item description/product images



Description

Material:

Black grey thermoplastic.

Version:

Steel parts black oxidised.

Note:

The hub cover is supplied unassembled.

The handwheels can be secured to a shaft using a transverse pin or by parallel key connection together with a DIN 6912 cap screw and a DIN 7349 washer.

Versions with transverse bore are secured using the ISO 4027 (DIN 914) grub screw.

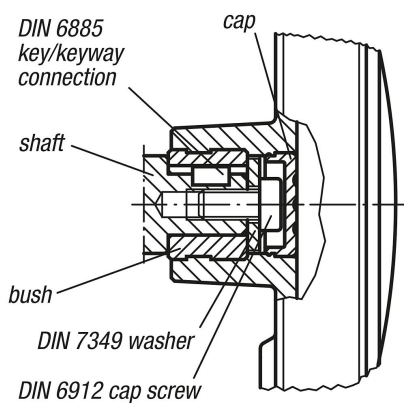

Drawings

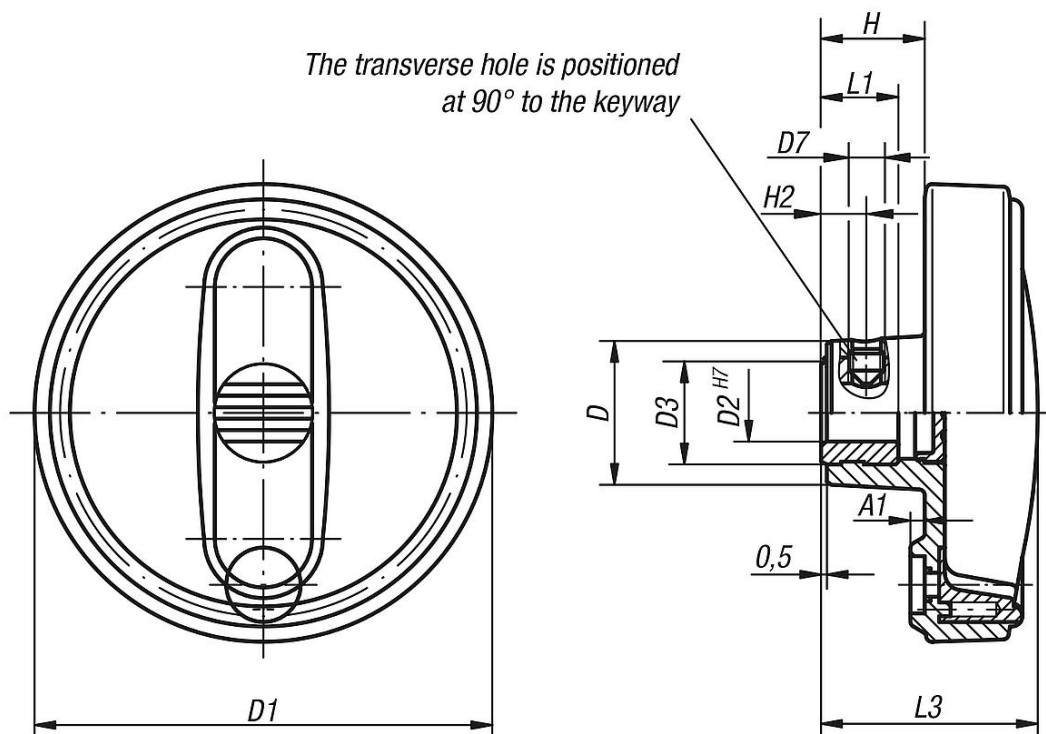

Drawings

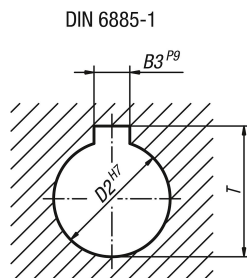

Overview of items

Handwheels

Order No.	Version 1	Version 2	D	D1	D2	D3	D7	A1	H	H2	L1	L3	B3	T
K0256.108008	reamed hole	without transverse hole	25	80	8H7	19	-	2,5	17,5	-	13	37,5	-	-
K0256.108010	reamed hole	without transverse hole	25	80	10H7	19	-	2,5	17,5	-	13	37,5	-	-
K0256.108012	reamed hole	without transverse hole	25	80	12H7	19	-	2,5	17,5	-	13	37,5	-	-
K0256.210010	reamed hole	without transverse hole	28	100	10H7	19	-	3	20	-	13	44	-	-
K0256.210012	reamed hole	without transverse hole	28	100	12H7	19	-	3	20	-	13	44	-	-
K0256.312512	reamed hole	without transverse hole	35	125	12H7	25	-	4	23,5	-	18,5	53	-	-
K0256.312514	reamed hole	without transverse hole	35	125	14H7	25	-	4	23,5	-	18,5	53	-	-
K0256.312516	reamed hole	without transverse hole	35	125	16H7	25	-	4	23,5	-	18,5	53	-	-
K0256.416014	reamed hole	without transverse hole	45	160	14H7	25	-	5,6	28	-	18,5	64,5	-	-
K0256.416016	reamed hole	without transverse hole	45	160	16H7	25	-	5,6	28	-	18,5	64,5	-	-
K0256.10800802	reamed hole with slot	without transverse hole	25	80	8H7	19	-	2,5	17,5	-	13	37,5	2	9
K0256.10801003	reamed hole with slot	without transverse hole	25	80	10H7	19	-	2,5	17,5	-	13	37,5	3	11,4
K0256.10801204	reamed hole with slot	without transverse hole	25	80	12H7	19	-	2,5	17,5	-	13	37,5	4	13,8
K0256.21001003	reamed hole with slot	without transverse hole	28	100	10H7	19	-	3	20	-	13	44	3	11,4
K0256.21001204	reamed hole with slot	without transverse hole	28	100	12H7	19	-	3	20	-	13	44	4	13,8
K0256.31251204	reamed hole with slot	without transverse hole	35	125	12H7	25	-	4	23,5	-	18,5	53	4	13,8
K0256.31251405	reamed hole with slot	without transverse hole	35	125	14H7	25	-	4	23,5	-	18,5	53	5	16,3
K0256.31251605	reamed hole with slot	without transverse hole	35	125	16H7	25	-	4	23,5	-	18,5	53	5	18,3
K0256.41601405	reamed hole with slot	without transverse hole	45	160	14H7	25	-	5,6	28	-	18,5	64,5	5	16,3
K0256.41601605	reamed hole with slot	without transverse hole	45	160	16H7	25	-	5,6	28	-	18,5	64,5	5	18,3
K0256.1080086	reamed hole	with transverse bore	25	80	8H7	19	M6	2,5	17,5	7,5	13	37,5	-	-
K0256.1080106	reamed hole	with transverse bore	25	80	10H7	19	M6	2,5	17,5	7,5	13	37,5	-	-
K0256.1080126	reamed hole	with transverse bore	25	80	12H7	19	M6	2,5	17,5	7,5	13	37,5	-	-
K0256.2100106	reamed hole	with transverse bore	28	100	10H7	19	M6	3	20	7,5	13	44	-	-
K0256.2100126	reamed hole	with transverse bore	28	100	12H7	19	M6	3	20	7,5	13	44	-	-
K0256.3125126	reamed hole	with transverse bore	35	125	12H7	25	M6	4	23,5	7,5	18,5	53	-	-
K0256.3125146	reamed hole	with transverse bore	35	125	14H7	25	M6	4	23,5	7,5	18,5	53	-	-
K0256.3125166	reamed hole	with transverse bore	35	125	16H7	25	M6	4	23,5	7,5	18,5	53	-	-
K0256.4160146	reamed hole	with transverse bore	45	160	14H7	25	M6	5,6	28	7,5	18,5	64,5	-	-
K0256.4160166	reamed hole	with transverse bore	45	160	16H7	25	M6	5,6	28	7,5	18,5	64,5	-	-
K0256.108008026	reamed hole with slot	with transverse bore	25	80	8H7	19	M6	2,5	17,5	7,5	13	37,5	2	9
K0256.108010036	reamed hole with slot	with transverse bore	25	80	10H7	19	M6	2,5	17,5	7,5	13	37,5	3	11,4
K0256.108012046	reamed hole with slot	with transverse bore	25	80	12H7	19	M6	2,5	17,5	7,5	13	37,5	4	13,8
K0256.210010036	reamed hole with slot	with transverse bore	28	100	10H7	19	M6	3	20	7,5	13	44	3	11,4
K0256.210012046	reamed hole with slot	with transverse bore	28	100	12H7	19	M6	3	20	7,5	13	44	4	13,8
K0256.312512046	reamed hole with slot	with transverse bore	35	125	12H7	25	M6	4	23,5	7,5	18,5	53	4	13,8
K0256.312514056	reamed hole with slot	with transverse bore	35	125	14H7	25	M6	4	23,5	7,5	18,5	53	5	16,3
K0256.312516056	reamed hole with slot	with transverse bore	35	125	16H7	25	M6	4	23,5	7,5	18,5	53	5	18,3
K0256.416014056	reamed hole with slot	with transverse bore	45	160	14H7	25	M6	5,6	28	7,5	18,5	64,5	5	16,3
K0256.416016056	reamed hole with slot	with transverse bore	45	160	16H7	25	M6	5,6	28	7,5	18,5	64,5	5	18,3

